

2008- CE
PHY
PAPER 2

MC



HONG KONG CERTIFICATE OF EDUCATION MOCK EXAMINATION 2008

PHYSICS PAPER 2 (MUTIPLE CHOICE)

By Wayne Leung

Time Allowed : 1 hour

1. Read carefully the instructions on the Answer Sheet . Stick a barcode label and insert the information required in the spaces provided.
2. When told to open this book, you should check that all the questions are there. Look for the words '**END OF PAPER**' after the last question.
3. All questions carry equal marks.
4. **ANSWER ALL THE QUESTIONS.** You should mark all your answers on the Answer Sheet.
5. You should mark only **ONE** answer to each question. If you mark more than one answer, you will receive **NO MARKS** for that question.
6. No marks will be deducted for wrong answers.

© 遵理學校 保留版權

Beacon College

All Rights Reserved

For questions 1. and 2.

The figure shows the velocity-time graph of a racing car traveling along a straight road.

下圖為跑車沿直路運動時的速度 - 時間關係線圖。

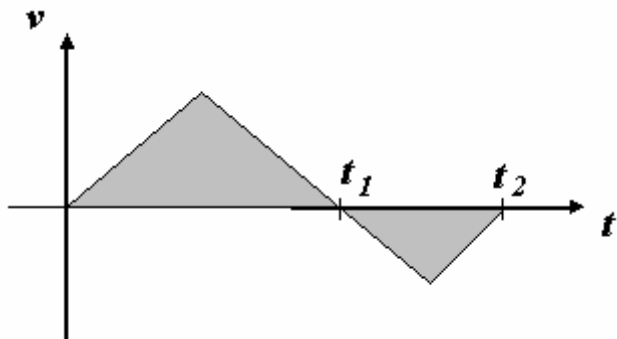

1. What physical quantity does the area of the shaded region represent?

- A. energy B. momentum
C. acceleration D. displacement

陰影部分的面積表示什麼物理？

- A. 能量 B. 動量
C. 加速度 D. 位移

2. Which of the following statements is/are incorrect?

- (1) The car changes its direction of travel at $t = t_1$.
(2) The car is farthest away from the starting point at $t = t_2$.
(3) The car returns to its starting point at $t = t_2$.

- A. (1) and (2) only B. (1) and (3) only
C. (2) and (3) only D. (1), (2) and (3)

下列各項敘述，哪些是不正確的？

- (1) 汽車在 $t = t_1$ 時改變行駛方向。
(2) 汽車在 $t = t_2$ 時離起點最遠。
(3) 汽車在 $t = t_2$ 時回到起點。

- A. 只有 (1)和(2) B. 只有 (1)和(3)
C. 只有 (2)和(3) D. (1)、(2)和(3)

3.

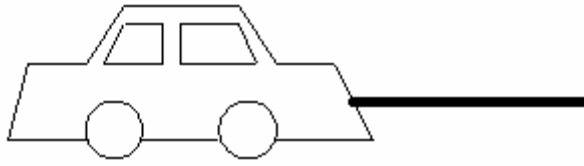

A broken-down car of mass 2000 kg is pulled by a truck and moves at a constant velocity 5 m s^{-1} along a horizontal road. It is known that the frictional force acting on the car is 200 N . Find the tension in the cable connecting the truck and the car.

一輛拖車拖動一輛待修的汽車，並沿水平路以恒速度 5 m s^{-1} 行駛。該輛汽車的質量為 2000 kg 。已知作用於汽車的摩擦力為 200 N 。求連接拖車和汽車的拖纜的張力。

- A. 0 N B. 200 N C. 10000 N
D. 10500 N

4.

Two objects of different masses are released from rest at the same height. Assume air resistance is negligible. Which of the following statements is/are correct?

- (1) A smaller gravitational force is acting on the object with smaller mass.
(2) They take different time to reach the ground.
(3) They have equal velocities when they reach the ground.

- A. (1) only B. (2) only C. (1) and (3) only
D. (1), (2) and (3)

將兩個不同質量的物體在同一高度由靜止釋放。設空氣阻力略去不計。下列各項敘述，哪些是正確的？

- (1) 質量較小的物體所受的重力較小。
(2) 它們到達地面所需的時間不同。
(3) 它們到達地面時的速度相等。

- A. 只有(1) B. 只有(2) C. 只有(1)和(3)
D. (1)、(2)和(3)

For questions 5. and 6

Two blocks *A* and *B* are connected by a light string passing over a smooth pulley as shown below. The mass of *A* is greater than that of *B*. The blocks are released from rest.

下圖顯示用一條通過滑輪的輕繩將兩個方塊 *A* 和 *B* 連接起來，其中 *A* 的質量較 *B* 的為大。現將兩個方塊從靜止狀態釋放。

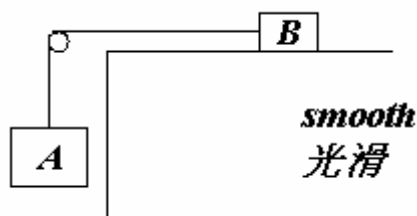

5. Which of the following pairs of physical quantities are equal while the blocks are in motion?

- A. the speeds of the blocks
- B. the accelerations of the blocks
- C. the resultant forces acting on the blocks
- D. the forces exerted by the string on the blocks

當兩個方塊運動時，下列哪一對物理量不相等的？

- A. 兩個方塊的速率
- B. 兩個方塊加速度
- C. 作用於兩個方塊合力
- D. 輕繩對兩個方塊作用力

6. Which of the following pairs of forces is an action and reaction pair?

- A. The force exerted by the string on *A* **and** The force exerted by string on *B*
- B. The force exerted by the string on *B* **and** The force exerted by *B* on the string
- C. The gravitational force exerted on *A* **and** The force exerted by *A* on the horizontal surface
- D. The gravitational force exerted on *B* **and** The force exerted by the string on *B*

以下哪一對是作用力和反作用力？

- A. 輕繩對 *A* 的作用力 和 輕繩對 *B* 的作用力
- B. 輕繩對 *B* 的作用力 和 *B* 對輕繩的作用力
- C. 作用於 *A* 的重力 和 *A* 對水平面的作用力
- D. 作用於 *B* 的重力 和 輕繩對 *B* 的作用力

7.

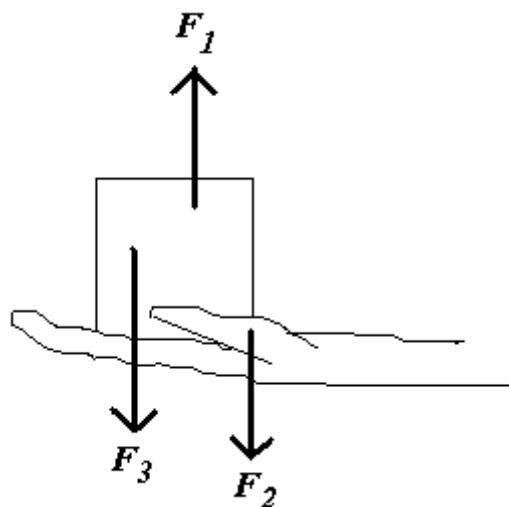

The above diagram shows a hand lifting a block vertically upwards with uniform acceleration.

Let F_1 be the force acting on the block by the hand,

F_2 be the force acting on the hand by the block,

F_3 be the gravitational force acting on the block.

Which of the following correctly describes the relation between the magnitudes of the forces?

上圖顯示某手以勻加速度垂直提起一木塊。

設 F_1 為手施於木塊的力，

F_2 為木塊施於手的力，

F_3 為施於木塊的重力。

以下哪一項正確描述這三個力的量值的關係？

A. $F_1 = F_3 > F_2$

B. $F_1 = F_2 > F_3$

C. $F_1 > F_2 = F_3$

D. $F_1 > F_2 > F_3$

8.

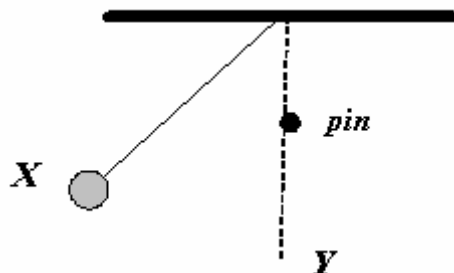

A pendulum bob is suspended by a light inextensible string. The bob is released from rest at a point X as shown above. When the bob reaches the lowest point Y , the string hits a fixed pin. Which of the following statements is/are correct?

- (1) The kinetic energy of the bob at X is equal to zero.
- (2) The highest level that the bob can reach is the level of the pin.
- (3) The work done by the tension of the string is zero throughout the motion.

- A. (2) only
- B. (3) only
- C. (1) and (2) only
- D. (1) and (3) only

用一根不會伸展的輕繩把一擺錘懸於空中。現將擺錘在 X 點從靜止釋放，如圖所示。當擺錘到達最低點 Y 時，輕繩碰到一根固定的長針。下列各項敘述，哪些是正確的？

- (1) 擺錘的動能在 X 點等於零。
- (2) 擺錘最高可上升至長針的水平。
- (3) 在整個運動過程中，繩子的張力沒有作功。

- A. 只有(2)
- B. 只有(3)
- C. 只有(1)和(2)
- D. 只有(1)和(3)

9.

A block is pulled along a horizontal bench at a constant velocity of 10 m s^{-1} by a force of 10 N. What is the work done against friction in 5 seconds?

一恆力以 10N 在水平桌上拉動一木塊以恆速 10 m s^{-1} 移動，求 5 秒內克服摩擦力的功？

- A. 500 J
- B. 200 J
- C. 50 J
- D. 12.5 J

10.

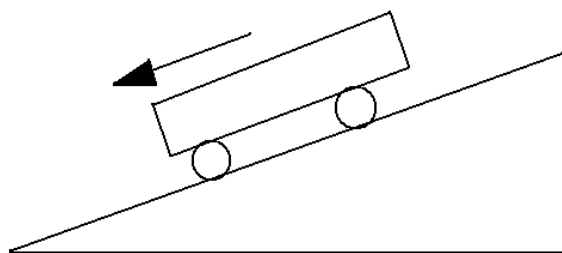

A trolley runs down a friction-compensated runway as shown above. Which of the following statements is wrong?

- A. The kinetic energy of the trolley increases with time.
- B. The potential energy of the trolley decreases with time.
- C. The sum of kinetic and potential energies of the trolley decreases.
- D. The frictional force acting on the trolley is not zero.

一輛小車沿有補償摩擦作用的跑道滑下，如上圖所示。下列哪項敘述是正確的？

- A. 小車的動能隨時間增加。
- B. 小車的勢能隨時間減少。
- C. 小車的動能和勢能之和減少。
- D. 作用於小車的摩擦力不等於零。

11.

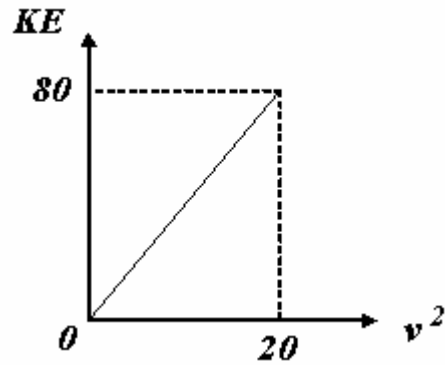

The above graph shows the variation of the kinetic energy E of an object with the square of its velocity v^2 . What is the momentum of the object when it is moving at a velocity 5 m s^{-1} ?

- A. 4 kg m s^{-1}
- B. 8 kg m s^{-1}
- C. 40 kg m s^{-1}
- D. It cannot be determined since the mass of the object is not given.

上圖顯示某物體的動能 E 和物體速度平方 v^2 的關係。當該物體以 5 m s^{-1} 的速度移動時，求它的動量。

- A. 4 kg m s^{-1}
- B. 8 kg m s^{-1}
- C. 40 kg m s^{-1}
- D. 由於不知道物體的質量，故無法計算。

12. Which of the following quantities is **not** a vector?

- A. Acceleration
- B. Momentum
- C. Weight
- D. Power

以下哪一個物理量不是向量？

- A. 加速度
- B. 動量
- C. 重量
- D. 功率

13. A car *A* of mass 100 kg moves with a speed of 20 m s^{-1} and makes a head-on collision with a car *B* of mass 300 kg, which was moving with a speed of 5 m s^{-1} in the opposite direction before the collision. If the two cars stick together after the collision, find their common velocity immediately after the collision.

- A. 1.25 m s^{-1} along the original direction of *A*
- B. 1.25 m s^{-1} along the original direction of *B*
- C. 8.75 m s^{-1} along the original direction of *A*
- D. 8.75 m s^{-1} along the original direction of *B*

一輛質量為 100 kg、速率為 20 m s^{-1} 的 *A* 車和另一輛質量為 300 kg、沿反方向以速率 5 m s^{-1} 行駛的 *B* 車迎頭碰撞。若碰撞後兩車黏合在一起，求它們碰撞後瞬間的共同速度。

- A. 以 1.25 m s^{-1} 沿 *A* 的原來方向前進
- B. 以 1.25 m s^{-1} 沿 *B* 的原來方向前進
- C. 以 8.75 m s^{-1} 沿 *A* 的原來方向前進
- D. 以 8.75 m s^{-1} 沿 *B* 的原來方向前進

14. A hot potato wrapped by shiny aluminium foil. By what means can the foil help reducing the rate of energy lost from the potato to the surrounding?

- (1) conduction
- (2) convection
- (3) radiation

- A. (2) only
- B. (3) only
- C. (1) and (2) only
- D. (1) and (3) only

一個用光亮鋁箔包裹著的熱馬鈴薯。鋁箔可以減少馬鈴薯以哪一種方式向周圍環境散失能量的率？

- (1) 傳導
- (2) 對流
- (3) 輻射

- A. 只有(2)
- B. 只有(3)
- C. 只有(1)和(2)
- D. 只有(1)和(3)

15. Water is used as a coolant in motor car engines because

- A. water has a low specific heat capacity.
- B. water has a high specific heat capacity.
- C. water has a low specific latent heat of vaporisation.
- D. water has a high specific latent heat of vaporisation.

水可用作汽車引擎的冷卻劑是因為

- A. 水的低比熱容。
- B. 水的高比熱容。
- C. 水的低汽化比潛熱。
- D. 水的高汽化比潛熱。

16. A cup of liquid P and a cup of liquid Q of equal mass are heated at the same rate. It is found that the temperature of P is rising at a rate slower than that of Q . Which of the following deductions is/are correct?

- (1) P has a higher specific latent heat of fusion than Q .
- (2) P has a higher boiling point than Q .
- (3) P has a higher specific heat capacity than Q .

- A. (1) only
- B. (3) only
- C. (1) and (2) only
- D. (2) and (3) only

現以相同的率向兩杯質量相等的液體 P 和 Q 加熱。結果顯示 P 的溫度上升率較 Q 為低。下列各項推論，哪些是正確的？

- (1) P 的熔解比潛熱較 Q 的高。
- (2) P 的沸點較 Q 的高。
- (3) P 的比熱容量較 Q 的高。

- A. 只有(1)
- B. 只有(3)
- C. 只有(1)和(2)
- D. 只有(2)和(3)

17.

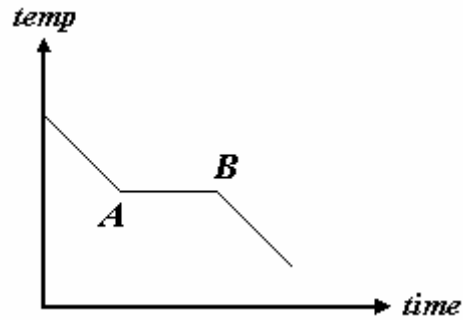

The figure above shows the cooling curve of a substance which is initially in the liquid state. The temperature of the substance remains unchanged during the period *AB*. Which of the following statements about the substance during the period *AB* is/are correct?

- (1) The substance is losing energy to the surroundings.
- (2) Latent heat is released by the substance.
- (3) The average potential energy of the molecules of the substance is increasing.

- A. (1) only
- B. (2) only
- C. (1) and (2) only
- D. (2) and (3) only

上圖顯示某物體的冷卻曲線，物體初時是呈液態的。物體的溫度於 *AB* 時段維持不變。下列各項有關物體於 *AB* 時段的敘述，哪些是正確的？

- (1) 物體散失能量到周圍環境中。
- (2) 物體釋放潛熱。
- (3) 物體內分子的平均勢能不斷增加。

- A. 只有(1)
- B. 只有(2)
- C. 只有(1)和(2)
- D. 只有(2)和(3)

18. A cup of tea is of mass 0.3 kg and temperature 50°C. If the specific heat capacity of the tea is $4000 \text{ J kg}^{-1} \text{ K}^{-1}$, find the minimum amount of ice at 0°C that should be added to the tea in order to lower its temperature to 0°C.

(Note: Specific latent heat of fusion of ice = $3.34 \times 10^5 \text{ J kg}^{-1}$.)

某杯茶的質量為 0.3 kg，溫度為 50°C。茶的比熱容量為 $4000 \text{ J kg}^{-1} \text{ K}^{-1}$ 。若要將該杯茶的溫度降低至 0°C，最少要在茶中加入多少 0°C 的冰塊？

註：冰的熔解比潛熱 = $3.34 \times 10^5 \text{ J kg}^{-1}$)

- A. 0.18 kg
- B. 0.20 kg
- C. 0.37 kg
- D. 0.84 kg

19. A wave source generates waves of frequency 100 Hz. How long does it take for the wave to travel 100 m?

- A. 0.1 s
- B. 1 s
- C. 1000 s
- D. It cannot be determined since insufficient information is given.

某波源產生頻率為 100 Hz 的波。這些波移動 100 m 的距離需時多久？

- A. 0.1 s
- B. 1 s
- C. 1000 s
- D. 由於資料不足，故無法計算。

20.

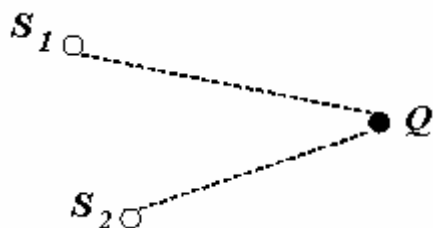

Two dippers S_1 and S_2 are connected to the same vibrator and produce identical waves in a ripple tank. Q is a point such that $S_1Q - S_2Q = 2\lambda$, where λ is the wavelength of the water waves generated. Which of the following statements is/are correct?

- (1) Constructive interference occurs at Q .
- (2) A crest is always formed at Q .
- (3) If the wavelength of the waves generated by the dippers is doubled, destructive interference will occur at Q .

- A. (1) only
- B. (2) only
- C. (1) and (3) only
- D. (2) and (3) only

兩個點振動源 S_1 和 S_2 連到同一個振動器，並在水波槽中產生相同的波。 Q 點恰在 $S_1Q - S_2Q = 2\lambda$ 處，其中 λ 為所產生水波的波長。下列各項敘述，哪些是正確的？

- (1) 在 Q 點會出現相長干涉。
- (2) 在 Q 點總是形成一個波峰。
- (3) 若將點振動源所產生水波的波長加大一倍，則在 Q 點會出現相消干涉。

- A. 只有(1)
- B. 只有(2)
- C. 只有(1)和(3)
- D. 只有(2)和(3)

21. A sonar on a ship is used to find the depth of the sea. An ultrasonic wave pulse is sent downwards from the ship towards the sea bed. The pulse travels with a speed of 1500 m s^{-1} in sea water. If the reflected pulse is received after 0.24 s , find the depth of the sea.

利用船上的聲納系統探測海床的深度。從船上向海床發出超聲波脈衝。已知該脈衝在海水中的速率為 1500 m s^{-1} 。若在 0.24 s 後收到反射脈衝，求海床的深度。

- A. 180 m
- B. 360 m
- C. 480 m
- D. 6250 m

22. Which of the following statements about light and sound is/are not correct?

- (1) Both light and sound are transverse waves.
- (2) Both light and sound travel slower in air than in water.
- (3) Both light and sound can undergo refraction when travelling from one medium to another.

- A. (1) only
- B. (3) only
- C. (1) and (2) only
- D. (2) and (3) only

下列有關光和聲音的敘述，哪些是不正確的？

- (1) 光和聲音都是橫波。
- (2) 光和聲音在空氣中的速率都比在水中的速率低。
- (3) 當由一個介質進入另一個介質時，光和聲音都可產生折射。

- A. 只有(1)
- B. 只有(3)
- C. 只有(1)和(2)
- D. 只有(2)和(3)

23. The frequencies of two musical notes X and Y are 300 Hz and 450 Hz respectively. If X and Y have the same amplitude, which of the following statements is/are true?

- (1) Y has a higher pitch than X .
- (2) The loudness of X is larger than that of Y .
- (3) The speed of Y is higher than that of X .

- A. (1) only
- B. (3) only
- C. (1) and (2) only
- D. (2) and (3) only

兩樂音 X 、 Y 的頻率分別為 300 Hz 和 450 Hz。若 X 和 Y 的振幅相同，下列各項敘述，哪些是正確的？

- (1) Y 的音調比 X 的高。
- (2) X 的響度比 Y 的強。
- (3) Y 的速率比 X 的高。

- A. 只有(1)
- B. 只有(3)
- C. 只有(1)和(2)
- D. 只有(2)和(3)

24.

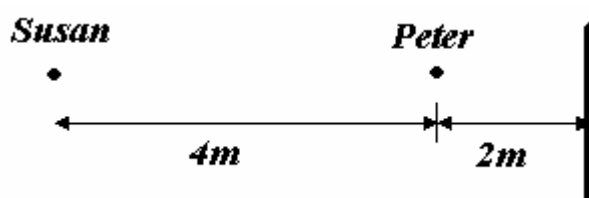

Peter stands 2 m in front of a plane mirror. Susan stands 4 m behind Peter as shown above. Find the distance between Susan and the image of Peter formed by the mirror.

如上圖所示，立德站在平面鏡前 2 m 處，而惠玲站在立德後面 4 m 處。求立德於鏡中所成的像和惠玲之間的距離。

- A. 4 m
- B. 6 m
- C. 8 m
- D. 12 m

25.

X-rays	A	visible light	B	microwaves
--------	---	------------------	---	------------

Part of the electromagnetic spectrum is shown above. Which of the following statements is/are correct?

- (1) *A* is ultra-violet and *B* is infra-red.
- (2) The wavelength of *A* is longer than that of *B*.
- (3) The speed of *A* in vacuum is lower than that of *B*.

- A. (1) only
- B. (3) only
- C. (1) and (2) only
- D. (2) and (3) only

上圖顯示部分電磁波譜。下列各項敘述，哪些是正確的？

- (1) *A* 為紫外光而 *B* 為紅外線。
- (2) *A* 的波長比 *B* 的長。
- (3) *A* 在真空中的速率比 *B* 的低。

- A. 只有(1)
- B. 只有(3)
- C. 只有(1)和(2)
- D. 只有(2)和(3)

26. Which of the following statements is/are true?

- (1) Light is a transverse wave.
- (2) Light can undergo diffraction.
- (3) Light transmits energy.

- A. (2) only
- B. (3) only
- C. (1) and (2) only
- D. (1), (2) and (3)

下列各項敘述，哪些是正確的？

- (1) 光是橫波。
- (2) 光可以產生繞射。
- (3) 光可輸送能量。

- A. 只有(2)
- B. 只有(3)
- C. 只有(1)和(2)
- D. (1)、(2)和(3)

27. An image of a big tree is formed by the surface of a pool of calm water. Which of the following phenomena explains the formation of the image?

- A. reflection
- B. total internal reflection
- C. refraction
- D. diffraction

一棵大樹於一池靜水表面所形成的像。以下哪種現象可用來解釋這個像的形成？

- A. 反射
- B. 全內反射
- C. 折射
- D. 繞射

28. Which of the following phenomena is/are caused by refraction of light?

- (1) A metre rule appears bent when dipped in water.
- (2) A swimming pool appears shallower than it really is.
- (3) A spectrum is formed when white light passes through a prism.

- A. (1) only
- B. (3) only
- C. (1) and (2) only
- D. (1), (2) and (3)

下列哪些現象是由光的折射所引致的？

- (1) 當米尺的一部分浸於水中，它看來像是折曲了。
- (2) 游泳池的深度看來較實際深度為淺。
- (3) 白光經過三稜鏡後形成光譜。

- A. 只有(1)
- B. 只有(3)
- C. 只有(1)和(2)
- D. (1)、(2)和(3)

29.

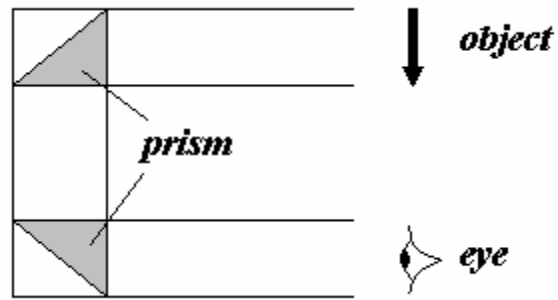

A student uses two prisms to construct a periscope as shown above. Which of the following shows the image of the object as seen by the observer?

某學生利用兩塊三稜鏡製成如上圖所示的潛望鏡。下列各圖，哪個正確顯示觀察者看到物體所成的像的形狀？

A.



B.



C.



D.



30.

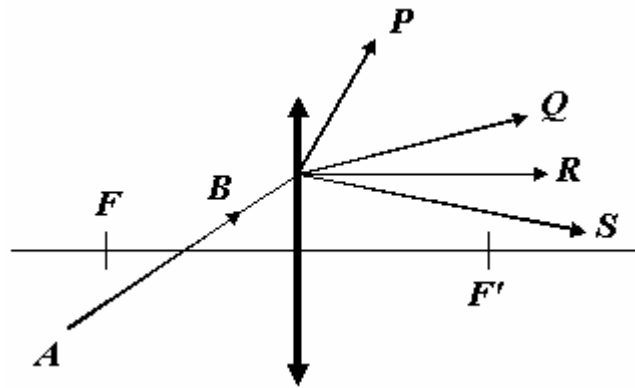

In the above diagram, F, F' are the foci of the convex lens and AB is an incident ray. Which of the following paths best represents the emergent ray?

上圖中、 $F、F'$ 為凸透鏡的焦點而 AB 為入射線。下列哪一路徑最能顯示其出射線？

- A. P
- D. S

B. Q

C. R

31.

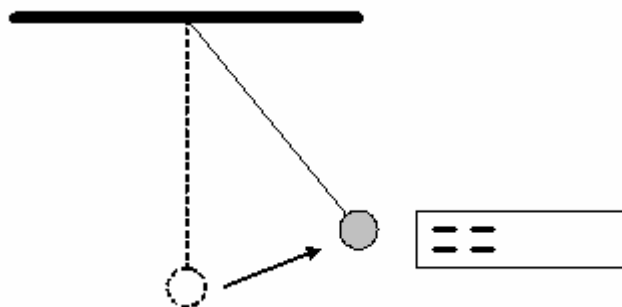

A small conducting sphere is suspended by an insulated thread. When a positively charged rod is brought near the sphere, the sphere is attracted as shown above. Which of the following is/are reasonable deduction(s)?

- (1) The sphere may carry a positive charge.
- (2) The sphere may carry a negative charge.
- (3) The sphere may be neutral.

- A. (1) only
- B. (2) only
- C. (1) and (2) only
- D. (1) and (3) only

一導電小球用絕緣線懸於空中。把一帶正電的棒移近該小球，小球會受到吸引，如上圖所示。下列哪些推論是合理的？

- (1) 小球可能帶正電。
- (2) 小球可能帶負電。
- (3) 小球可能是中性的。

- A. 只有 (1)
- B. 只有 (2)
- C. 只有 (1) 和 (2)
- D. 只有 (1) 和 (3)

32.

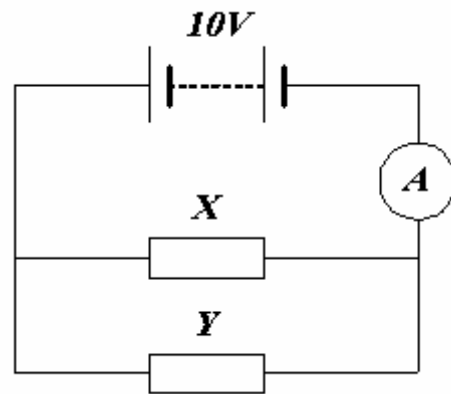

A resistor and a bulb are connected in parallel to a 10V battery as shown above. The reading of the ammeter is 7 A. If the power dissipated by the resistor X is 25 W, find the power dissipated by the resistor Y .

如上圖所示，一個電阻器和一個燈泡並聯接至 10V 的電池組。安培計的讀數 7A。若電阻器 X 所消耗的功率為 25W，求電阻器 Y 所消耗的功率。

- A. 9W
- B. 18W
- C. 27W
- D. 45W

33.

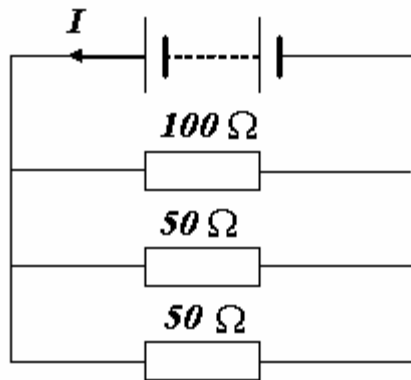

In the above circuit, the current delivered by the cell is I . What is the current passing through the $100\ \Omega$ resistor?

以上電路圖中，電池輸出的電流為 I 。求通過 $100\ \Omega$ 電阻器的電流。

- A. $\frac{1}{2}I$
- B. $\frac{1}{4}I$
- C. $\frac{5}{4}I$
- D. $\frac{1}{5}I$

34.

Operating voltage 220 V / 50 Hz	
Power	400W

The above diagram shows the label attached to a TV. Which of the following statements is/are true when the TV is working at its rated value?

- (1) The resistance of the TV is 121Ω .
- (2) The TV draws a current of 5A from the mains supply.
- (3) The TV consumes 1 kWh of electrical energy in 5 hours.

- A. (1) only
- B. (2) only
- C. (1) and (3) only
- D. (2) and (3) only

上圖顯示某電視機上的標籤。若該電視機按額定值使用，下列各項敘述，哪些是正確的？

- (1) 電視機的電阻為 121Ω 。
- (2) 市電電源供應給電視機的電流為 5A。
- (3) 電視機在 5 小時內消耗的電能為 1kWh。

- A. 只有(1)
- B. 只有(2)
- C. 只有(1)和(3)
- D. 只有(2)和(3)

35. One day, Donald used the following electrical appliances at home:

Appliance	Rating	Duration	Cost of electricity
Electric heater	220V, 2500W	45 minutes	C_1
Television	220V, 300W	3 hours	C_2
Lamp	220V, 250W	7 hours	C_3

Which of the following relations is correct?

某天，文強在家中使用下列電器：

電器	額定值	使用時間	電費
電熱器	220V, 2500W	45 分鐘	C_1
電視	220V, 300W	3 小時	C_2
電燈	220V, 250W	7 小時	C_3

下列關係式中，哪一項是正確的？

- A. $C_1 > C_2 > C_3$
- B. $C_2 > C_1 > C_3$
- C. $C_1 > C_3 > C_2$
- D. $C_3 > C_2 > C_1$

36. Two electrical heaters X and Y are of ratings '220V, 50W' and '220V, 100W' respectively. Which of the following deductions about the two heaters is/are correct?

- (1) The operating resistance of X is twice that of Y.
- (2) X will consume a power of 12.5 W when it is connected to a 110V mains supply.
- (3) Both heaters work at their rated values when they are connected in series to a 440V mains supply.

- A. (1) only B. (3) only C. (1) and (2) only
D. (2) and (3) only

兩個電熱器 X、Y 的額定值分別為「220V，50W」和「220V，100W」。下列各項有關兩電熱器的推論，哪些是正確的？

- (1) X 的操作電阻為 Y 的兩倍。
- (2) 若將 X 連接 110V 市電電源，它的耗電功率為 12.5W。
- (3) 若將 X、Y 串聯接至 440V 市電電源，兩電熱器均按其額定值工作。

- A. 只有(1) B. 只有(3) C. 只有(1)和(2)
D. 只有(2)和(3)

37. For a simple motor, which of the following changes can increase the turning effect of the coil?

- (1) using a stronger magnet
- (2) reducing the resistance of the rheostat
- (3) using a coil with a larger number of turns

- A. (1) and (2) only B. (1) and (3) only
C. (2) and (3) only D. (1), (2) and (3)

下列哪些改動可以增強一部簡單的電動機線圈的轉動效果？

- (1) 改用更強的磁鐵
- (2) 減小變阻器的電阻
- (3) 改用匝數較多的線圈

- A. 只有(1)和(2) B. 只有(1)和(3)
C. 只有(2)和(3) D. (1)、(2)和(3)

38.

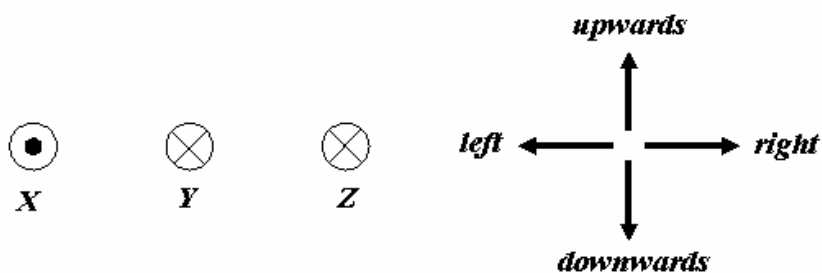

The above diagram shows the cross-section of three parallel wires X, Y and Z. X carries a current flowing out of the paper and Y and Z carries a current flowing into paper. What is the direction of the resultant force acting on Y?

- A. towards the left
- B. towards the right
- C. upwards
- D. downwards

上圖顯示三條平行的載電流直導線 X、Y 和 Z 的橫截面。X 的電流流出紙面，而 Z 和 Y 的電流流入紙面。作用於 Y 的合力的方向為何？

- A. 指向左
- B. 指向右
- C. 指向上
- D. 指向下

39. Which of the following statements about direct current (d.c.) and alternating current (a.c.) is/are not correct?

- (1) All d.c. sources produce constant voltages.
- (2) The direction of current in an a.c. circuit changes with time
- (3) Both d.c. and a.c. produce a heating effect in a resistor.

- A. (1) only B. (2) only C. (1) and (3) only
D. (2) and (3) only

下列有關直流電和交流電的敘述，哪些是不正確的？

- (1) 所有直流電源均提供恒電壓。
- (2) 在交流電路中，電流的方向隨時間而改變。
- (3) 直流電和交流電均會在電阻器產生熱效應。

- A. 只有(1)
B. 只有(2)
C. 只有(1)和(3)
D. 只有(2)和(3)

40. Which of the following correctly shows the major energy change in the device when it is working?

	Device	From	To
A.	A microphone	sound	electrical
B.	A loudspeaker	sound	electrical
C.	A dynamo	electrical	electrical
D.	A transformer	mechanical	electrical

下列哪一項正確顯示某器件操作時主要的能量變換？

	器件	由	轉變為
A.	收音器	聲音	電能
B.	揚聲器	聲音	電能
C.	發電機	電能	電能
D.	變壓器	機械能	電能

41. A 5 V a.c. supply is stepped up to 10 V by a transformer. If the current in the primary coil is 3 A and the power loss of the transformer is 2 W, find the current in the secondary coil.

一變壓器把 5 V 交流電源提升至 10 V。若通過原線圈的電流為 3 A 而變壓器損耗的功率為 1.2 W，求通過副線圈的電流。

- A. 0.04 A B. 0.16 A C. 0.26 A D. 1.3 A

42. Which of the following statements about long distance power transmission at high alternating voltages are correct?

- (1) Alternating voltages can be stepped up or down efficiently by transformers.
- (2) For a given transmitted power, the current will be increased if a high voltage is adopted.
- (3) The power loss in the transmission cables will be reduced if a high voltage is adopted.

- A. (1) and (2) only B. (1) and (3) only
C. (2) and (3) only D. (1), (2) and (3)

下列有關以交流高壓作長距離輸電的敘述，哪些是正確的？

- (1) 用變壓器可以有效地將交流電升壓或降壓。
- (2) 對於一定的輸送功率而言，如果使用高壓輸電，傳輸電流就會增加。
- (3) 如果用高壓輸電，在傳輸電纜上的功率損耗會減小。

- A. 只有(1)和(2)
B. 只有(1)和(3)
C. 只有(2)和(3)
D. (1)、(2)和(3)

43.

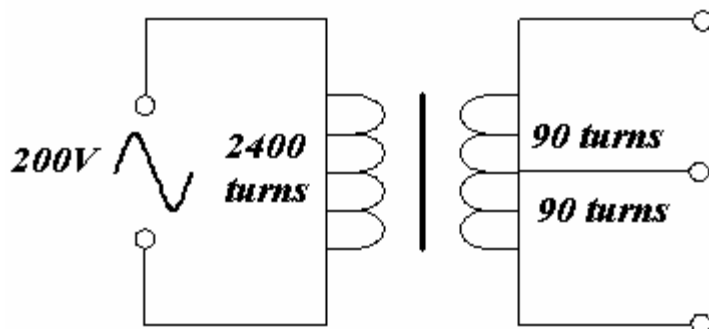

The primary coil of a transformer has 2400 turns and is connected to a 200 V a.c. supply. The secondary coil has 180 turns, which can be tapped at different points as shown above.

A '20W, 10V' light bulb is connected to the transformer so that it works at its rated value.

Which of the following statements is/are correct?

- (1) The bulb should be connected to points PQ.
- (2) The current through the bulb is 2 A.
- (3) If the efficiency of the transformer is 80%, the current in the primary coil is 0.125 A.

- A. (1) only B. (2) only C. (1) and (3) only
D. (2) and (3) only

一變壓器的原線圈有 2400 匝，並接上 200 V 交流電源。變壓器的副線圈有 180 匝，且有幾個接線頭，如上圖所示。一個「20 W，10 V」的燈泡接上變壓器，使它按額定值工作。下列各項敘述，哪些是正確的？

- (1) 燈泡應接上點 P 和 Q。
- (2) 通過燈泡的電流為 2 A。
- (3) 若變壓器的效率為 80%，通過原線圈的電流為 0.125 A。

- A. 只有(1)
B. 只有(2)
C. 只有(1)和(3)
D. 只有(2)和(3)

44.

A radioactive isotope ${}_{92}^{250}\text{X}$ undergoes a series of decay processes to form a daughter nuclide ${}_{90}^{234}\text{Y}$. How many α -particles and β -particles have been emitted in this decay process?

	<u>No. of α-particles</u>	<u>No. of β-particles</u>
A.	4	6
B.	4	7
C.	4	8
D.	6	4

放射性同位素 ${}_{92}^{250}\text{X}$ 經過一系列衰變後，產生子核素 ${}_{90}^{234}\text{Y}$ 。在這衰變過程中共放出了多少粒 α 粒子和 β 粒子？

	<u>α 粒子數目</u>	<u>β 粒子數目</u>
A.	4	6
B.	4	7
C.	4	8
D.	6	4

45.

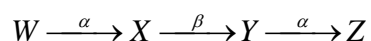

A radioactive nuclide W decays to a nuclide Z by emitting one α - and two β - particles as shown above. Which of the following statements about nuclides W , X , Y and Z is/are correct?

- (1) W and Y are isotopes.
- (2) Y has the greatest atomic number.
- (3) W has the greatest mass number.

- A. (1) only
- B. (3) only
- C. (1) and (2) only
- D. (2) and (3) only

放射核素 W 衰變為核素 Z ，在過程中放出一個 α 粒子和兩個 β 粒子，如上圖所示。下列關於核素 W 、 X 、 Y 和 Z 的敘述，哪些是正確的？

- (1) W 和 Y 是同位素。
- (2) Y 和原子序數最大。
- (3) W 的質量數最大。

- A. 只有(1)
- B. 只有(3)
- C. 只有(1)和(2)
- D. 只有(2)和(3)